

Nistune Z32 ECU Modifications for R33 RB25DET Skyline Installation

Revision 6 – 14Sep10



Thanks to Eric at DTA Motorsports, Skyline Stu and Andrew H for their help.

Overview

The Z32 ECU is a functional and cost effective way to tune the R33 RB25DET Skyline when fitted with a NISTune board. The Z32 ECU can actually be used to run the RB25 without modification (if Z32 AFM is used). This is fine for track/race vehicles but there are signals which differ. So for best integration into a standard R33 Skyline we've provided some basic instructions detailing the changes. *It's recommended to do the resistor modification to correct the Fuel Temp input even for race vehicles (see Section 6).*

These are the steps to perform if modifying the Z32 ECU for a direct R33 plug-in. This saves re-wiring the R33 harness - which means the standard ECU can easily be re-fitted if required. The same outcome may be realised by modifying the wiring harness if you'd rather not modify the ECU.

NISTune has provided a base image which consists of the Z32 base with R33 maps/tables merged. The file is called **Z32_transplanted_R33maps_merged.ENT**. This provides a good starting point for tuning. Our experience shows that an RB25DET running the standard 370cc injectors (but with Z32 AFM fitted) will run quite well before any tuning even takes place.

Notes

1) R33 Series 1 RB25 does not use a switch on the Throttle Position Sensor (TPS) to sense closed throttle. In this situation when installing a Z32 ECU, it will use default "limp" values to determine TPS idle indication. This works quite effectively provided TPS is adjusted correctly. (Section 3 covers the modification for these series engines).

R33 Series 2 uses a switch on the TPS so will work the same with the Z32 ECU

2) We recommend Z32 (8 bit) ECU's for this modification. These can be any JDM , EDM or 1990-1992 USDM model ECU. It does not matter if the ECU is naturally aspirated or turbo, manual or auto.

(Nissan part numbers 23710-30Pxx, 31Pxx, 37Pxx, 40Pxx, 41Pxx, 46Pxx, 47Pxx and 48Pxx).

Avoid later model USDM (1993-1996) 16 bit Z32 ECU's (Nissan part numbers 23710-45Pxx, 53Pxx, 51Pxx).

3) Note that most USDM Z32 ECU's are not stamped with a Nissan part number. However there is a manufacturer (JECS) part number which begins with A18. We can work out the Nissan part number if you contact us with the JECS part number, or you can connect to the ECU using any consult tool to retrieve the Nissan part number.

Instructions provided involve modifications to the ECU circuit board. Do not attempt this unless you are proficient in this type of work. No responsibility taken for information provided. Double check your work and continuity check all modifications on the ECU connector before using in the vehicle!

1) Knock Sensor inputs – pin 23/24

The R33 RB25 engine uses twin knock sensors with Nissan part number 22060-56S10 (shared with R32 RB20DET). Z32 VG30 only uses a single knock sensor but with different Nissan part number 22060-30P00 (shared with various SR20 engines).

As a result only one knock sensor will be active if Z32 ECU is left stock. RB25 knock sensor wires 23 (cylinder 1-3) and 24 (cylinder 4-6) are fed to single knock sensor input (pin 23) on the Z32 ECU. Benefits are that knock sensing from both knock sensors is used.

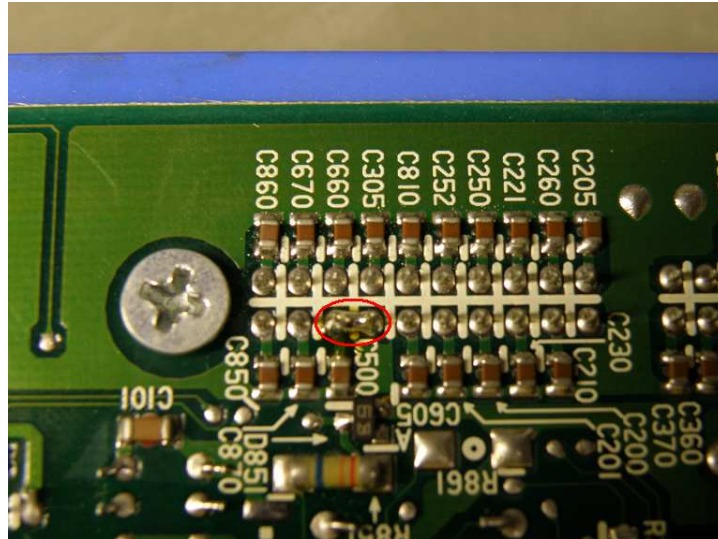

Solder pins 23 and 24 together

** If knock sensing is over sensitive, then it has been found during tuning to provide the ECU with false positives of knock, resulting in timing is pulled and using knock maps. In this case then it may be necessary to either disable knock sensing or attempt using SR20 knock sensors with the Z32 ECU*

4) Power Steer switch input – pin 19/34

RB25 power steering input goes to pin 19. This pin is used to drive the rad fan relay on Z32, so this signal must be moved to the Z32 power steer input pin (pin 34). This is achieved by linking across to the correct pin and then isolating the original pin by cutting a track on the board.

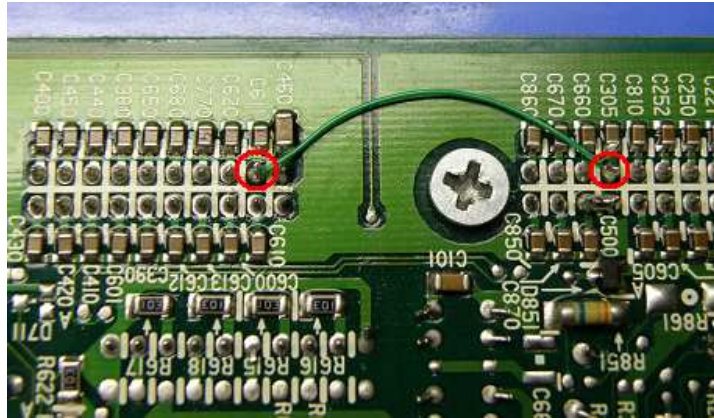

Link pins 19 - 34

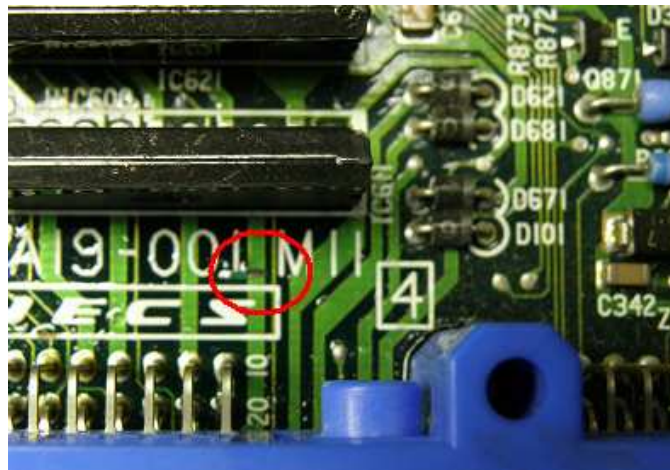

Cut track on top side of ECU

5) FICD output – pin 33 * *Series 1 R33 only*

The R33 Series 1 RB25 engine uses pin 33 for the Exhaust Overtemp Lamp on the dash. This line should be disconnected as the Z32 uses this line to drive the FICD (Fast Idle Control Device) – for idle up when aircon is on. FICD is driven separately on the R33 Series 1 RB25 via the aircon system.

Note that the R33 Series 2 RB25 does use the FICD the same as the Z32 ECU, so this modification is not required for those engines

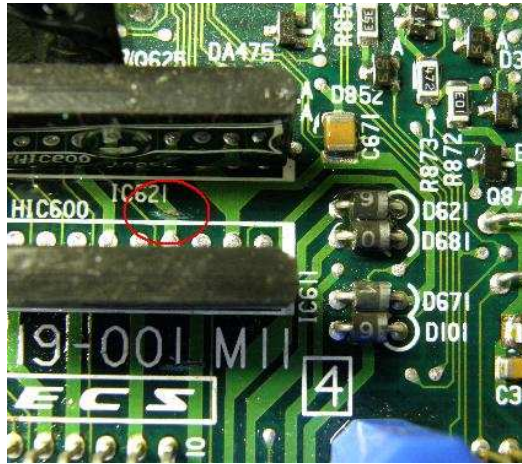

1Cut track near IC621 (5 pins from left)

** Only applicable to Series 1 R33's. Series 2 R33's drive FICD from this pin - the same as Z32, so this modification is not required.*

6) Fuel Temperature input – pin 36 *

Z32 uses a fuel temperature sensor. RB25 does not - and the matching pin does not have a wire connected. A Diagnostic Trouble Code (DTC) will be raised by the Z32 ECU if it senses that the voltage on this pin is out of range. This input can be simulated by fitting a 2 K resistor between pin 36 and GND (pin 30) – which will give a reading of around 25 degrees fuel temp (other values can also be used eg: 1K = 40 degrees).

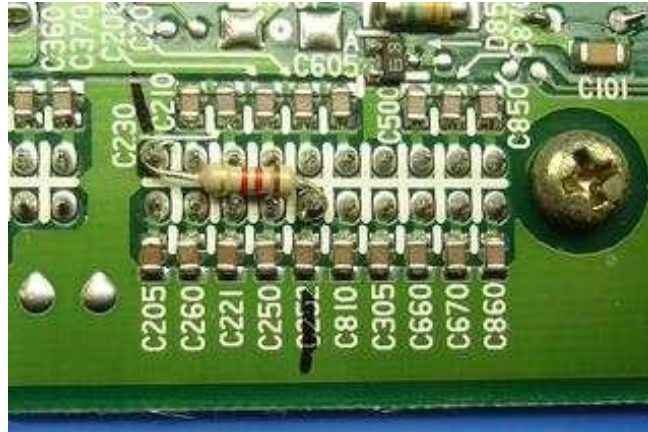

** Series 2 R33's have the FICD wired to this pin. If this connection remains then the Fuel Temp signal will be incorrect and FICD will not function. The FICD wire must therefore be moved from pin 36 to pin 33. The wire may either be cut/soldered or (better) the pin removed from pin 36 and inserted into pin 33.*

7) Injectors/IGN signals

Swapping of injector/IGN signals is not required. Although the pin assignments on the ECU's are different, when the Z32 ECU is used with R33 RB25DET wiring loom, the injector banks correspond with the intended injection order. So no modification is required.

Supporting Data

ECU CONNECTOR PIN NUMBERING

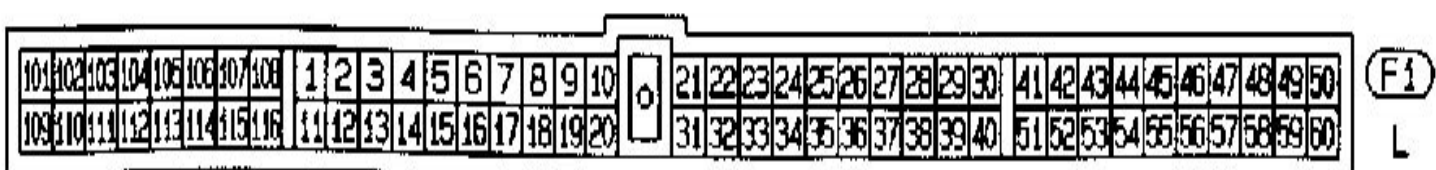

Z32 ECCS DIAGRAM

ENGINE AND EMISSION CONTROL OVERALL SYSTEM

Circuit Diagram

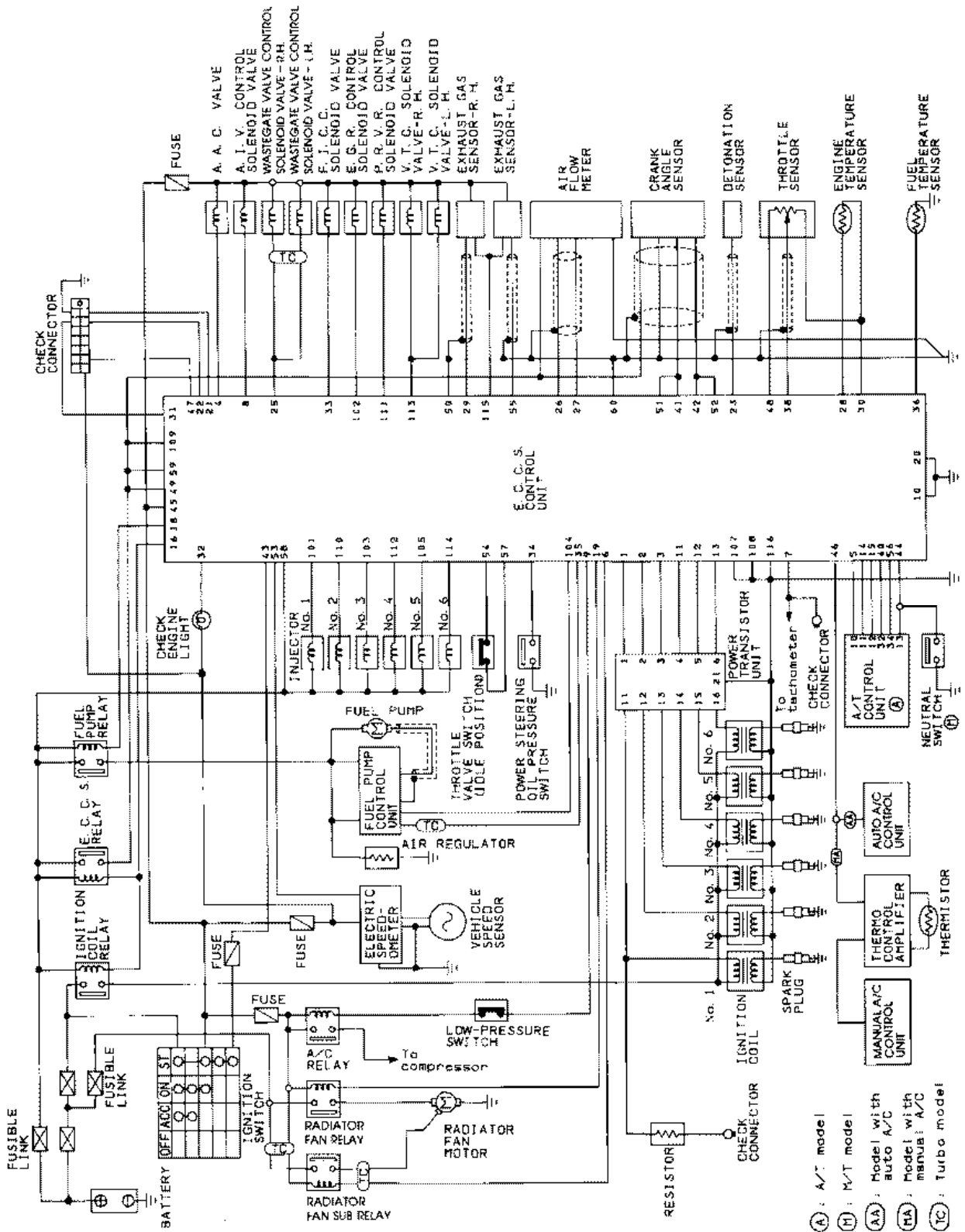

SEF352K

R33 (Series 1) ECCS DIAGRAM

SYSTEM OUTLINE

RB25DE / RB25DET ENGINE

1. CIRCUIT DIAGRAM (RB25DE / RB25DET)

